



ROCKET FUEL FOR SALES.



Display Advertising – Rates, Specifications & Deadlines

THE OPEN ROAD ADVERTISING RATES

Rates effective January 2009*	Full Colour rates					
	Casual	+ GST	2-4	+ GST	5+	+ GST
DPS	48,550	53,405	46,120	50,732	43,700	48,070
Full Page	24,275	26,702.50	23,060	25,366	21,850	24,035
1/2 page	14,805	16,285.50	14,065	15,471.50	13,325	14,657.50
1/3 page	10,875	11,962.50	10,330	11,363	9,790	10,769
1/4 page (Horizontal)	8,715	9,586.50	8,280	9,108	7,845	8,629.50

Loadings:	Inside front cover/inside back	20%	Other specified position	+10%
	Outside back cover	25%	Right hand page first half	+15%

HOLIDAY ACCOMMODATION

		GST
5 lines + 2 months on web site with email or web link	\$300	\$330
Each additional line in magazine	\$50	\$55
Logo (2 centimetres)	\$325	\$357.50
Colour (per colour)	\$50	\$55
Full colour	\$200	\$220

HOLIDAY ACCOM DISPLAY

- 1 COLUMN WIDTH = 3.4 cm (mono)		GST
2 cm deep x 1 column	\$440	\$484
3 cm deep x 1 column	\$630	\$693
4 cm deep x 1 column	\$820	\$902
5 cm deep x 1 column	\$1,010	\$1,111
6 cm deep x 1 column	\$1,200	\$1,320

MARKET PLACE

			GST
5.6cm x 4.1 cm	(56mm x 41mm)	\$882	\$970.20
6cm x 1 column	(60mm x 57mm)	\$1,990	\$2,189
9cm x 1 column	(90mm x 57mm)	\$2,985	\$3,283.50
6cm x 2 column	(60mm x 118mm)	\$3,980	\$4,378
6cm x 3 column	(60mm x 175mm)	\$5,970	\$6,567
12cm x 1 column	(120mm x 57mm)	\$3,980	\$4,378
12cm x 2 column	(120mm x 118mm)	\$7,960	\$8,756

(4 – 6 insertion less 10%)

Issue	* Booking & Cancellation deadline	Material Deadline	Insert samples by	Insert to printer	Delivery to home
2009 Sept/Oct	20 July	3 August	14 August	21 August	3-25 September
2009 Nov/Dec	21 September	3 October	16 October	23 October	3-25 November
2010 Jan/Feb	9 November	23 November	1 December	8 December	3-25 January
2010 Mar/Apr	9 January	30 January	12 February	19 February	3-25 March
2010 May/June	12 March	26 March	9 April	16 April	3-25 May
2010 July/Aug	10 May	24 May	11 June	18 June	3-25 July
2010 Sept/Oct	13 July	27 July	13 August	20 August	3-25 September
2010 Nov/Dec	13 September	27 September	15 October	22 October	3-25 November

*PLEASE NOTE: Deadlines and rates are subject to change and advertisers will be notified in advance of any amendments.



ROCKET FUEL FOR SALES.

open road

Inserts – Rates, Specifications & Deadlines

THE OPEN ROAD INSERT RATES

RATES (based on 10 gram weight)		GST
150,000 to 199,999	\$105 per `000	\$115.50
200,000 to 499,999	\$80 per `000	\$88
500,000 plus	\$55 per `000	\$60.50

Please call our sales team for prices on: Inserts over 10 grams, Tip-ons, Bound inserts, Posters, Wraparound booklets, Zip outs, Sealed sections, and so much more.

*If you would like us to organise the printing of your insert, at very competitive prices, please contact our Production department 02 8741 6683.

INSERT BREAKDOWN

Full run	1,545,000
Metro	889,000
Regional	755,000

The Open Road offers the option of targeting inserts by postcode. There are 12 Regional and 16 Metro postcode groups. For example, South Western Suburbs, which is then broken into 4 sub regions: Strathfield, Villawood, Liverpool and Campbelltown.

*A full insert region breakdown is available on request.

SPECIFICATIONS

Magazine trim size	275 mm (d) x 200 mm (w)
Minimum supply size	100 mm x 100 mm
Maximum supply size	257 mm x 180 mm

If an insert exceeds 16 pages, the above dimensions may not be suitable. Please consult Production prior to proceeding.

Minimum weight of paper

Single sheet, minimum size	100 gsm
Single sheet, maximum size	90 gsm
Four page folder	60 gsm
Eight pages or more	60 gsm

Folding

Folded inserts must have a "closed" or leading edge to enable automatic feeding on the collator. Concertina folds are not suitable. The above information is intended as a guide only. It may be possible to insert products which fall outside these guidelines and we will be able to advise on the suitability of any samples submitted.

CONTACTS

Advertising: Katherine Komorowski M: 0404 048 480
T: 02 8741 6692 F: 02 8741 6698
E: katherine.komorowski@mynrma.com.au

Classifieds: Fiona Fyfe T: 02 8741 6696 F: 02 8741 6698
E: fiona@openroad.com.au

Production: Jo McIntyre T: 02 8741 6683 F: 02 8741 6698
E: jo@openroad.com.au

Issue	* Booking & Cancellation deadline	Material Deadline	Insert samples by	Insert to printer	Delivery to home
2009 Sept/Oct	20 July	3 August	14 August	21 August	3-25 September
2009 Nov/Dec	21 September	3 October	16 October	23 October	3-25 November
2010 Jan/Feb	9 November	23 November	1 December	8 December	3-25 January
2010 Mar/Apr	9 January	30 January	12 February	19 February	3-25 March
2010 May/June	12 March	26 March	9 April	16 April	3-25 May
2010 July/Aug	10 May	24 May	11 June	18 June	3-25 July
2010 Sept/Oct	13 July	27 July	13 August	20 August	3-25 September
2010 Nov/Dec	13 September	27 September	15 October	22 October	3-25 November

*PLEASE NOTE: Deadlines and rates are subject to change and advertisers will be notified in advance of any amendments.



MOTORING + SERVICES

helping people



ROCKET FUEL FOR SALES.



TECHNICAL SPECIFICATIONS

NRMA Publishing accepts only digital material. All material must be supplied formatted for the Apple Macintosh OSX platform. All images should be of a high resolution (eg. 300dpi JPEG format).

We accept files saved in the following formats:

Adobe Photoshop at 300dpi or larger (saved as EPS, JPEG, TIFF or PSD). Adobe Illustrator saved as EPS files up to Version 11.0. Adobe Indesign documents up to Version 13.0. PDF files at 300dpi or better.

NB. artwork embedded in or saved as MS Word or PowerPoint documents or files will not be accepted. We do not accept Truetype fonts. Crop marks and 5mm of bleed around artwork must be included on display advertisements.

Delivery formats:

- CD-ROM / DVD- ROM
- Email
- Quickcut
- Websend

Proofs:

All material must be accompanied by a suitable high quality colour proof (Chemical, IRIS, High Resolution Digital).

No responsibility will be taken for colour matching, material integrity or finished advertisement print quality if a colour proof is not supplied.

Material delivery:

Clearly mark all material with Open Road and the issue date

Send to:

Open Road

NRMA
Level 1
8 George Street
North Strathfield NSW 2137

Email: jo@openroad.com.au

PUBLISHERS' CONDITIONS

Payment required within 30 days of publication. Agency commission: 10% of the gross (excluding production charges). Cancellation of booked advertising cannot be accepted after booking confirmation closing date. Publishers are not responsible for errors due to changes made after material closing date. Rates given are on the basis that space ordered is used within 12 months and that material is supplied as per conditions set out herein. All copy is subject to the approval of the publishers. When the copy is overdue, the publishers reserve the right to repeat previous copy. The publishers reserve the right to reject or cancel any advertising at any time for any reason and will not be held responsible for unclaimed material after a period of three months from date of publication. If an advertiser has booked space or advertising in The Open Road and fails to deliver the copy by the copy deadline, the advertiser will be charged the full advertising rate as if the advertisement had been run (excludes earlier notice of cancellation before copy deadline).

MECHANICAL DETAILS

Column depth

240mm

Column width

1 Column 56mm
3 Columns 176mm

Trimmed size

Double page spread 275mm deep x 400mm wide
Full page 275mm deep x 200mm wide

Bleed size

Double page spread 285mm deep x 410mm wide
Full page 285mm deep x 210mm wide

Live type size

Double page spread 265mm deep x 390mm wide
Full page 265mm deep x 190mm wide

Live type/Trim size

Half page (horizontal) 120mm deep x 176mm wide
Half page (vertical) 275mm deep x 100mm wide
Quarter page 60mm deep x 176mm wide
Third page (vertical) 240mm deep x 56mm wide
Third page (horizontal) 90mm deep x 176mm wide
Bleed sizes on request.

Outside back cover dimensions

Type 275mm deep x 120mm wide
Trim 275mm deep x 130mm wide
Bleed 285mm deep x 135mm wide
(NB: Bleed on foredge only).

Extra charges

Reproduction, alteration and make-up charges on application.

Note: The dimensions below do not apply to the Holiday Accommodation section or Market Place.

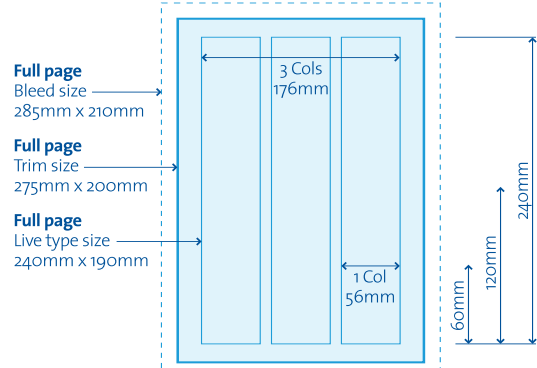



ROCKET FUEL FOR SALES.

open road

Inserts – Rates, Specifications & Deadlines

INSERT SPECIFICATIONS

Delivery instructions

PACKAGING

Pallets will be accepted where they meet the following guidelines:

- Goods with laps or pasted areas must be packed to prevent sticking or curling.
- Inserts, Tip-ons and Onserts must be bundled the same way up.
- Quarto sections for binding may be delivered in tied logs each 92cm long with end boards, or may be uniformly stacked with masonite or similar placed on top of the pallet base, between every 3rd tier and finally on the top of the stack.
- Shrink wrapping must be tight and cover the entire pallet.
- Pallets should be strapped with 4 straps (2 each way) with a board or pallet top.
- Smaller inserts may be packed as described on this page or packed flat in cartons.
- Sachets must be packed flat with separators, in a uniform direction, securely and in shallow cartons (100 mm deep).
- Cartons must not exceed 12 kg.
- Loose inserts must be stacked, not logged.
It is the responsibility of the client to ensure that:
 - The required quantity of inserts is delivered to the printer.

- The supplier clarifies all figures and weighs the product prior to despatch.
- Pallets are numbered consecutively.
- Each pallet holds equal quantities (except for the last pallet).

Labelling instructions

All product must arrive labelled including the following:

- The Open Road
- Insert title
- Issue date
- Total quantity expected
- Quantity per pallet/carton
- Total number of pallets/cartons
- Key number where applicable

Terms and conditions

*All bookings are subject to the Terms and Conditions of Advertising.

*If inserts fail to arrive in time for publication, if cancelled after the specified deadline or are cancelled due to any deviation from the technical specifications then the full rate will be charged.

Freight Instructions

Deliver all material to
Hannan Print
55 Doody Street Alexandria NSW 2015.
Attention: Ray Blackwood.

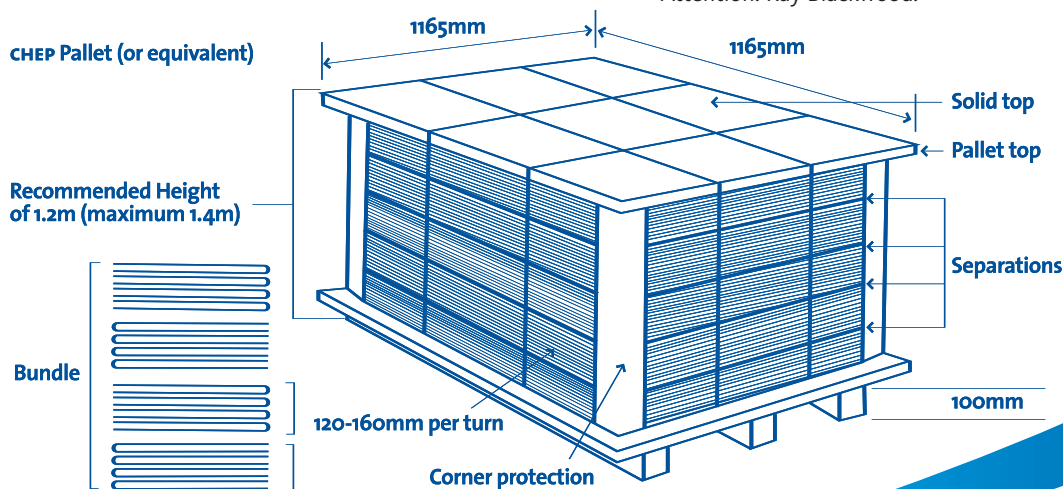

MOTURING + SERVICES

helping people